



XTV Series

XTV1285 Datasheet

12V Top Terminal VRLA-AGM

Specifications

Voltage (Vdc)	12
Ah Capacity (8-Hr 1.75 VPC @ 25°C)	8.00
Ah Capacity (20-Hr 1.75 VPC @ 25°C)	8.80
Ah Capacity (8-Hr 1.80 VPC @ 25°C)	7.84
Max Charge Current (A)	2.55
Max Discharge Current (A)	130 (5 sec)
Short Circuit Current (A)	288 (5 sec)
Internal Resistance (mΩ)	Approx. 20.9
Terminal Type	F2 terminal - Faston Tab 250
Terminal Torque	--
Container Material	ABS (UL 94-HB) & Flame Retardant (94-V0) available upon request
Weight (kg. / lb.)	2.62 / 5.77
Length (L) (mm / in)	150.9±2.0 / 5.94±0.08
Width (W) (mm / in)	64.8±1.0 / 2.55±0.04
Height (H) (mm / in)	98.6±1.0 / 3.88±0.04
Design Life	Up to 12 Years in Standby Service at 25°C. Eurobat (20°C): >12 Years Very Long Life
Operating Temperature	Nominal: 25°C (77°F) Discharge: -15°C - 50°C (5°F-122°F) Charge/Storage: -15°C - 40°C (5°F - 104°F)
Float Charging Voltage	13.5 - 13.8 Vdc/battery 25°C (77°F)
Eq. Charging Voltage	14.4 - 15.0 Vdc/battery 25°C (77°F)
Self-Discharge	Less than 10% after 90 days, can be stored up to 6 months and 10 months with equalization charge* at 25°C (77°F); Full recharging is required before usage, and charged sooner if stored at higher temperature than 25°C (77°F).



Valve Regulated Lead Acid (VRLA) Battery

Maintenance-Free, Absorbent Glass Mat (AGM) Technology for Efficient Gas Recombination of up to 99%

Pure Lead Construction and Proprietary Elements

Designed for Float Service Standby Power Applications in Extreme Temperature Environments

Built in Accordance with IEC 60896-21/22:2004, UL1973 Listed (MH66728) and UL1989 Recognized (MH14533)

Certified by TUV NORD according to ISO 9001:2015





XTV Series

XTV1285 Datasheet

12V Top Terminal VRLA-AGM

Constant Current Discharge Characteristics Per Battery: Amperes (25°C, 77°F)

F.V/Time	30MIN	60MIN	90MIN	2HR	3HR	5HR	8HR	10HR	12HR	20HR	24HR	48HR
10.02V (1.67VPC)	9.64	5.62	4.10	3.25	2.34	1.52	1.01	0.83	0.71	0.45	0.38	0.19
10.50V (1.75VPC)	9.42	5.53	4.05	3.21	2.31	1.50	1.00	0.82	0.70	0.44	0.37	0.19
10.80V (1.80VPC)	9.12	5.40	3.97	3.15	2.27	1.47	0.98	0.81	0.69	0.43	0.36	0.19

Constant Power Discharge Characteristics Per Battery: Watts (25°C, 77°F)

F.V/Time	30MIN	60MIN	90MIN	2HR	3HR	5HR	8HR	10HR	12HR	20HR	24HR	48HR
10.02V (1.67VPC)	110	65.0	47.7	37.8	27.3	18.0	12.0	9.84	8.36	5.29	4.46	2.31
10.50V (1.75VPC)	108	64.2	47.3	37.5	27.0	17.8	11.8	9.75	8.28	5.24	4.42	2.29
10.80V (1.80VPC)	105	62.9	46.5	36.9	26.7	17.5	11.7	9.61	8.16	5.17	4.36	2.25

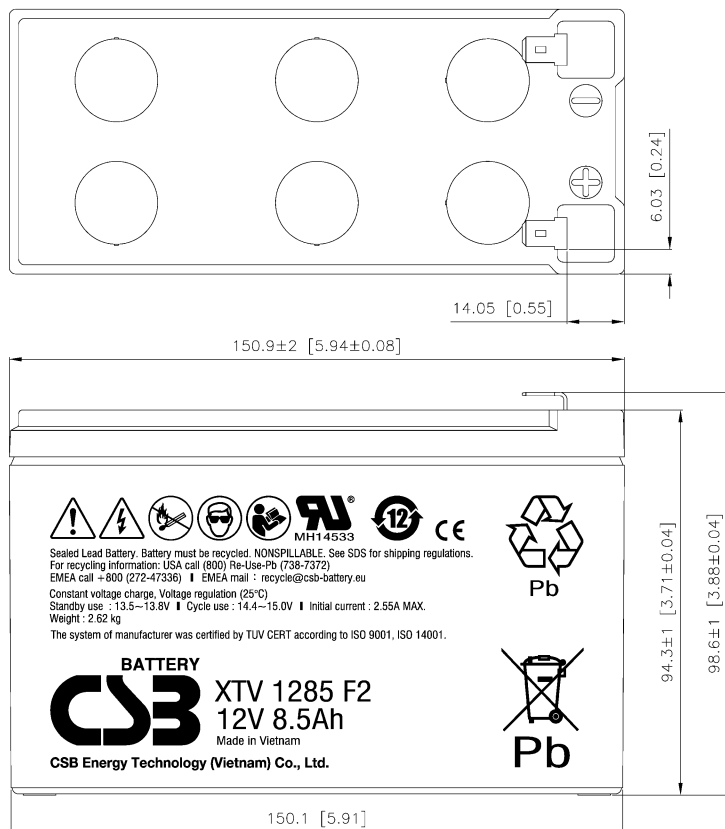

Detail A Drawing(3:1)

