



UPS Series

UPS12580 Datasheet

12V Top Terminal VRLA-AGM

Specifications

Voltage (Vdc)	12
Watts Per Cell (30-Sec 1.67 VPC @ 25°C)	--
Watts Per Cell (5-Min 1.67 VPC @ 25°)	94.17
Watts Per Cell (15-Min 1.67 VPC @ 25°)	43.50
Max Charge Current (A)	4.80
Max Discharge Current (A)	130 (5sec)
Short Circuit Current (A)	575
Internal Resistance	Approx. 11.80 mΩ
Terminal Type	F2 terminal - Faston Tab 250 *
Terminal Torque	--
Container Material	ABS (UL 94-HB) & Flame Retardant (94-V0) available upon request
Weight (kg. / lb., Approx.)	2.83 / 6.24
Length (L) (mm / in)	150.9±2.0 / 5.94±0.08
Width (W) (mm / in)	64.8±1.0 / 2.55±0.04
Height (H) (mm / in)	98.6±1.0 / 3.88±0.04
Design Life	Up to 5 Years in Standby Service at 25°C. Eurobat (20°C): 3-5 Years Standard Commercial
Operating Temperature	Nominal: 25°C (77°F) Discharge: -15°C - 50°C (5°F-122°F) Charge/Storage: -15°C - 40°C (5°F - 104°F)
Float Charging Voltage	13.5 - 13.8 Vdc/battery 25°C (77°F)
Eq. Charging Voltage	14.4 - 15.0 Vdc/battery 25°C (77°F)
Self-Discharge	Less than 10% after 90 days, can be stored up to 6 months and 10 months with equalization charge* at 25C (77F); Full recharging is required before usage, and charged sooner if stored at higher temperature than 25C (77F).



Valve Regulated Lead Acid (VRLA) Battery

Maintenance-Free, Absorbent Glass Mat (AGM) Technology for Efficient Gas Recombination of up to 99%

Pure Lead Construction and Proprietary Elements

Designed for High-Rate UPS, Float Service Standby Power Applications

Built in Accordance with IEC 61056-1/2:2012, UL1973 Listed (MH66728) and UL1989 Recognized (MH14533)

Certified by TUV NORD according to ISO 9001:2015





UPS Series

UPS12580 Datasheet

12V Top Terminal VRLA-AGM

Constant Current Discharge Characteristics Per Battery: Amperes (25°C, 77°F)

F.V/Time	2MIN	4MIN	5MIN	6MIN	8MIN	10MIN	15MIN	20MIN	30MIN	45MIN	60MIN	90MIN
10.02V (1.67 VPC)	85.3	60.2	51.7	45.6	37.6	31.7	22.7	18.1	13.0	9.30	7.33	5.20
10.50V (1.75 VPC)	73.6	53.7	47.2	42.2	35.6	30.1	22.1	17.5	12.7	9.05	7.11	5.03
10.80V (1.80 VPC)	66.1	48.8	43.2	39.3	33.2	28.4	21.1	16.9	12.4	8.82	6.92	4.91

Constant Power Discharge Characteristics Per Battery: Watts (25°C, 77°F)

F.V/Time	2MIN	4MIN	5MIN	6MIN	8MIN	10MIN	15MIN	20MIN	30MIN	45MIN	60MIN	90MIN
10.02V (1.67 VPC)	877	643	565	504	420	356	261	206	149	107	84.0	58.9
10.50V (1.75 VPC)	808	601	538	481	402	343	254	203	147	105	83.1	58.4
10.80V (1.80 VPC)	750	568	505	458	383	329	245	197	145	104	81.7	57.6

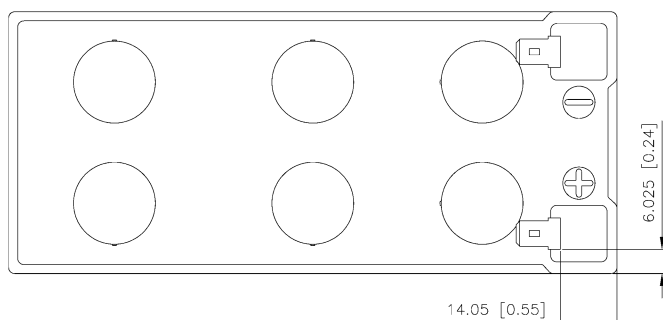

Detail A Drawing(3:1)

