



# HRL Series

## HRL12150WG Datasheet

12V Top Terminal VRLA-AGM

### Specifications

Voltage (Vdc)	12
Watts Per Cell (30-Sec 1.67 VPC @ 25°C)	--
Watts Per Cell (5-Min 1.67 VPC @ 25°)	271
Watts Per Cell (15-Min 1.67 VPC @ 25°)	156
Max Charge Current (A)	15.0
Max Discharge Current (A)	225
Short Circuit Current (A)	1116
Internal Resistance (mΩ)	Approx. 7.30
Terminal Type	I2 thread lead alloy terminal to accept M6 bolt
Terminal Torque	51.7±10.3 Kgf·cm / 44.9±9.0 Lbf·in / 5.10±1.0 N·m
Container Material	ABS (UL 94-HB) & Flame Retardant (94-V0) available upon request
Weight (kg. / lb., Approx.)	11.95 / 26.34
Length (L) (mm / in)	195.6±2.0 / 7.70±0.08
Width (W) (mm / in)	130.0±1.5 / 5.12±0.06
Height (H) (mm / in)	172.0±2.0 / 6.77±0.08
Design Life	Up to 10 Years in Standby Service at 25°C. Eurobat (20°C): >12 Years Very Long Life
Operating Temperature	Nominal: 25°C (77°F) Discharge: -15°C - 50°C (5°F-122°F) Charge/Storage: -15°C - 40°C (5°F - 104°F)
Float Charging Voltage	13.5 - 13.8 Vdc/battery 25°C (77°F)
Eq. Charging Voltage	14.4 - 15.0 Vdc/battery 25°C (77°F)
Self-Discharge	Less than 10% after 90 days, can be stored up to 6 months at 25°C (77°F); Fully recharging is required before usage, and charged sooner if stored at higher temperature than 25°C (77°F).



Valve Regulated Lead Acid (VRLA) Battery

Maintenance-Free, Absorbent Glass Mat (AGM) Technology for Efficient Gas Recombination of up to 99%

Pure Lead Construction and Proprietary Elements

Designed for High-Rate UPS, Float Service Standby Power Applications

Built in Accordance with IEC 61056-1/2:2012, UL1973 Listed (MH66728) and UL1989 Recognized (MH14533)

Certified by TUV NORD according to ISO 9001:2015





# HRL Series

## HRL12150WG Datasheet

12V Top Terminal VRLA-AGM

### Constant Current Discharge Characteristics Per Battery: Amperes (25°C, 77°F)

F.V/Time	2MIN	4MIN	5MIN	6MIN	8MIN	10MIN	15MIN	20MIN	30MIN	45MIN	60MIN	90MIN
10.02V (1.67 VPC)	--	--	152	139	116	107	82.2	66.3	48.4	35.3	28.6	20.5
10.50V (1.75 VPC)	--	--	132	122	104	96.8	76.0	62.0	45.7	33.6	27.8	20.0
10.80V (1.80 VPC)	--	--	119	111	96.2	90.0	71.1	58.4	43.8	32.2	26.8	19.5

### Constant Power Discharge Characteristics Per Battery: Watts (25°C, 77°F)

F.V/Time	2MIN	4MIN	5MIN	6MIN	8MIN	10MIN	15MIN	20MIN	30MIN	45MIN	60MIN	90MIN
10.02V (1.67 VPC)	--	--	1624	1494	1275	1182	935	753	559	415	334	239
10.50V (1.75 VPC)	--	--	1422	1321	1149	1075	877	704	530	399	325	231
10.80V (1.80 VPC)	--	--	1302	1217	1069	1006	825	675	507	383	314	226

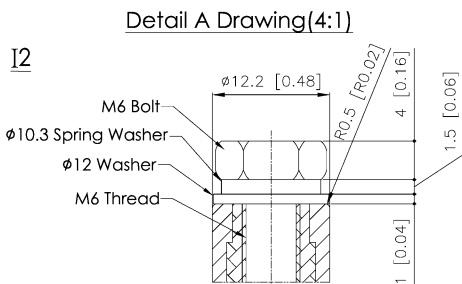
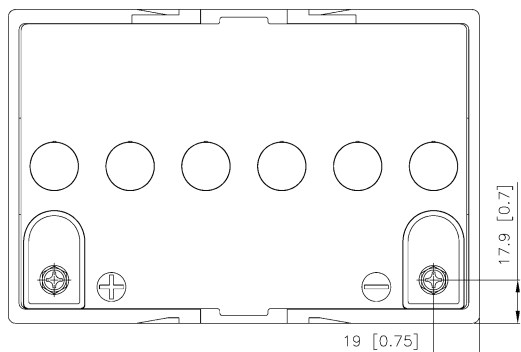

[M6 Bolt & M6 Thread & Washer & Spring Washer]

