



GPL Series

GPL12800 Datasheet

12V Top Terminal VRLA-AGM

Specifications

Voltage (Vdc)	12
Ah Capacity (8-Hr 1.75 VPC @ 25°C)	75.04
Ah Capacity (20-Hr 1.75 VPC @ 25°C)	80.80
Ah Capacity (8-Hr 1.80 VPC @ 25°C)	73.36
Max Charge Current (A)	24.00
Max Discharge Current (A)	800 (5sec)
Short Circuit Current (A)	1933
Internal Resistance	Approx. 4.0 mΩ
Terminal Type	I2 thread lead alloy terminal to accept M6 bolt
Terminal Torque	51.7±10.3 Kgf-cm / 44.9±9.0 Lbf-in / 5.10±1.0 N-m
Container Material	PP (UL 94-HB) & Flame Retardant (94-V0) available upon request
Weight (kg. / lb., Approx.)	25.60 / 56.42
Length (L) (mm / in)	261.0±2.5 / 10.28±0.10
Width (W) (mm / in)	168.5±2.0 / 6.63±0.08
Height (H) (mm / in)	213.5±2.5 / 8.41±0.10
Design Life	Up to 10 Years in Standby Service at 25°C. Eurobat (20°C): >12 Years Very Long Life
Operating Temperature	Nominal: 25°C (77°F) Discharge: -15°C - 50°C (5°F-122°F) Charge/Storage: -15°C - 40°C (5°F - 104°F)
Float Charging Voltage	13.5 - 13.8 Vdc/battery 25°C (77°F)
Eq. Charging Voltage	14.4 - 15.0 Vdc/battery 25°C (77°F)
Self-Discharge	Less than 10% after 90 days, can be stored up to 6 months and 10 months with equalization charge* at 25C (77F); Full recharging is required before usage, and charged sooner if stored at higher temperature than 25C (77F).



Valve Regulated Lead Acid
(VRLA) Battery

Maintenance-Free, Absorbent
Glass Mat (AGM) Technology for
Efficient Gas Recombination of
up to 99%

Pure Lead Construction and
Proprietary Elements

Designed for Float Service
Standby Power Applications

Built in Accordance with IEC
60896-21/22:2004, UL1973
Listed (MH66728) and UL1989
Recognized (MH14533)

Certified by TUV NORD
according to ISO 9001:2015





GPL Series

GPL12800 Datasheet

12V Top Terminal VRLA-AGM

Constant Current Discharge Characteristics Per Battery: Amperes (25°C, 77°F)

F.V/Time	5MIN	10MIN	15MIN	30MIN	60MIN	90MIN	2HR	3HR	5HR	8HR	10HR	20HR
10.02V (1.67 VPC)	274	191	146	86.7	53.2	38.6	30.7	21.7	14.4	9.46	7.78	4.13
10.50V (1.75 VPC)	234	170	139	84.4	51.4	37.4	29.9	21.4	14.1	9.38	7.63	4.04
10.80V (1.80 VPC)	210	158	131	81.9	50.2	36.8	29.5	21.0	13.8	9.17	7.55	3.97

Constant Power Discharge Characteristics Per Battery: Watts (25°C, 77°F)

F.V/Time	5MIN	10MIN	15MIN	30MIN	60MIN	90MIN	2HR	3HR	5HR	8HR	10HR	20HR
10.02V (1.67 VPC)	2818	2060	1635	996	612	452	365	260	172	115	92.9	49.4
10.50V (1.75 VPC)	2553	1927	1558	976	603	447	361	257	170	113	92.3	49.0
10.80V (1.80 VPC)	2371	1815	1478	949	592	440	356	254	168	111	91.0	48.7

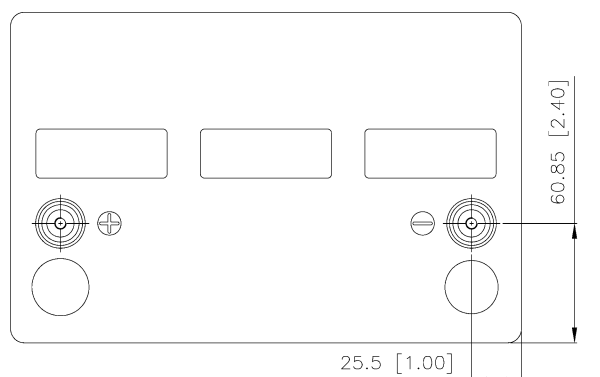

Detail A Drawing(4:1)

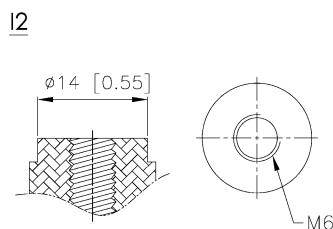

[M6 bolt]

