



# GP Series

## GP12120 Datasheet

12V Top Terminal VRLA-AGM

### Specifications

Voltage (Vdc)	12
Ah Capacity (8-Hr 1.75 VPC @ 25°C)	11.2
Ah Capacity (20-Hr 1.75 VPC @ 25°C)	12.0
Ah Capacity (8-Hr 1.80 VPC @ 25°C)	10.96
Max Charge Current (A)	3.60
Max Discharge Current (A)	180
Short Circuit Current (A)	378
Internal Resistance (mΩ)	Approx. 16.7
Terminal Type	F2 terminal - Faston Tab 250*
Terminal Torque	--
Container Material	ABS (UL 94-HB) & Flame Retardant (94-V0) available upon request.
Weight (kg. / lb., Approx.)	3.67 / 8.09
Length (L) (mm / in)	151.0±2.0 / 5.94±0.08
Width (W) (mm / in)	98.0±1.0 / 3.86±0.04
Height (H) (mm / in)	100.3±1.5 / 3.95±0.06
Design Life	Up to 5 Years in Standby Service at 25°C. Eurobat (20°C): 3-5 Years Standard Commercial
Operating Temperature	Nominal: 25°C (77°F) Discharge: -15°C - 50°C (5°F-122°F) Charge/Storage: -15°C - 40°C (5°F - 104°F)
Float Charging Voltage	13.5 - 13.8 Vdc/battery 25°C (77°F)
Eq. Charging Voltage	14.4 - 15.0 Vdc/battery 25°C (77°F)
Self-Discharge	Less than 10% after 90 days, can be stored up to 6 months at 25°C (77°F); Fully recharging is required before usage, and charged sooner if stored at higher temperature than 25°C (77°F).



Valve Regulated Lead Acid (VRLA) Battery

Maintenance-Free, Absorbent Glass Mat (AGM) Technology for Efficient Gas Recombination of up to 99%

Pure Lead Construction and Proprietary Elements

Designed for Float Service Standby Power Applications

Built in Accordance with IEC 61056-1/2:2012, UL1973 Listed (MH66728) and UL1989 Recognized (MH14533)

Certified by TUV NORD according to ISO 9001:2015





# GP Series

## GP12120 Datasheet

12V Top Terminal VRLA-AGM

### Constant Current Discharge Characteristics Per Battery: Amperes (25°C, 77°F)

F.V/Time	5MIN	10MIN	15MIN	30MIN	60MIN	90MIN	2HR	3HR	5HR	8HR	10HR	20HR
10.02V (1.67 VPC)	48.2	32.0	23.6	13.7	8.12	5.84	4.62	3.35	2.21	1.44	1.18	0.62
10.50V (1.75 VPC)	43.3	30.0	22.6	13.4	8.03	5.77	4.57	3.26	2.13	1.40	1.15	0.60
10.80V (1.80 VPC)	38.8	28.0	21.5	13.0	7.81	5.64	4.48	3.17	2.06	1.37	1.14	0.59

### Constant Power Discharge Characteristics Per Battery: Watts (25°C, 77°F)

F.V/Time	5MIN	10MIN	15MIN	30MIN	60MIN	90MIN	2HR	3HR	5HR	8HR	10HR	20HR
10.02V (1.67 VPC)	515	342	265	159	97.7	70.2	55.6	39.3	25.2	16.6	13.7	7.63
10.50V (1.75 VPC)	462	326	256	156	96.1	69.3	54.9	38.5	24.4	16.2	13.4	7.54
10.80V (1.80 VPC)	418	307	243	153	94.8	68.0	53.7	37.7	24.1	15.8	13.1	7.42

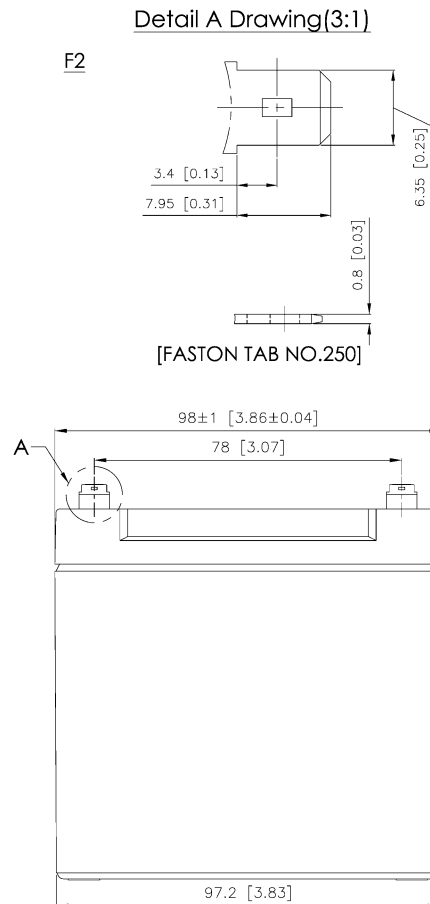
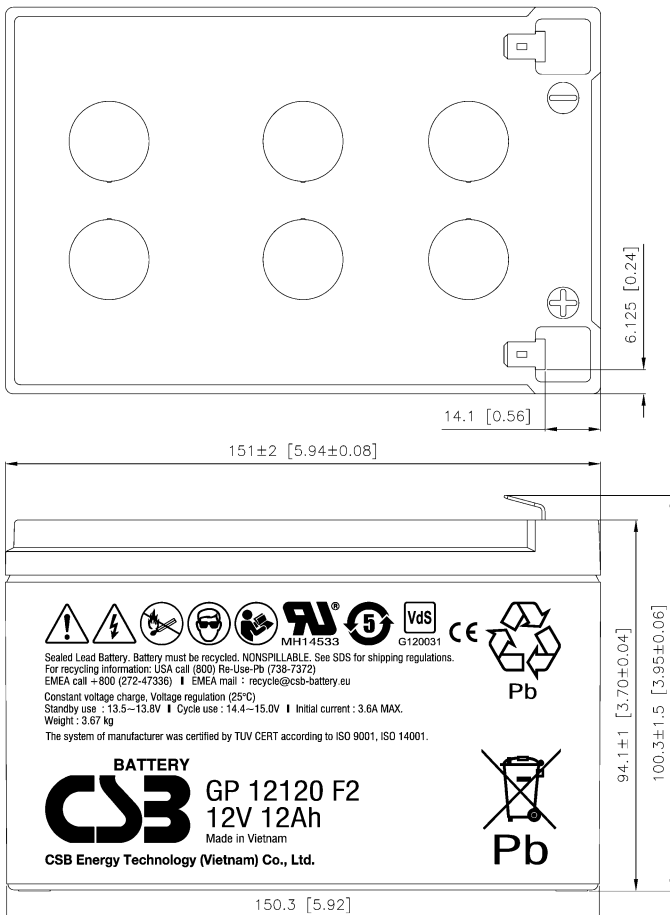

\* F1 terminal is available, Max Discharge Current = 150 A