



# EVX Series

## EVX12340 Datasheet

12V Top Terminal VRLA-AGM



Valve Regulated Lead Acid (VRLA) Battery

Maintenance-Free, Absorbent Glass Mat (AGM) Technology for Efficient Gas Recombination of up to 99%

Pure Lead Construction and Proprietary Elements

Designed for E-mobility or deep cycling applications

Built in Accordance with IEC 60254-1:2005 / IEC60254-2:2008, UL1973 Listed (MH66728) and UL1989 Recognized (MH14533)

Certified by TUV NORD according to ISO 9001:2015



### Specifications

Voltage (Vdc)	12
Ah Capacity (8-Hr 1.75 VPC @ 25°C)	27.68
Ah Capacity (20-Hr 1.75 VPC @ 25°C)	34.40
Ah Capacity (8-Hr 1.80 VPC @ 25°C)	27.28
Max Charge Current (A)	10.20
Max Discharge Current (A)	400 (5sec)
Short Circuit Current (A)	--
Internal Resistance	Approx. 9.2 mΩ
Terminal Type	B5 terminal to accept M6 nut & bolt
Terminal Torque	51.7±10.3 Kgf·cm / 44.9±9.0 Lbf·in / 5.1±1.0 N·m
Container Material	ABS (UL 94-HB)
Weight (kg. / lb., Approx.)	10.77 / 23.74
Length (L) (mm / in)	195.6±2.0 / 7.70±0.08
Width (W) (mm / in)	130.0±1.5 / 5.12±0.06
Height (H) (mm / in)	178.3±2.0 / 7.02±0.08
Design Life	400 cycles @ 100%DOD at 25°C 1800 cycles @ 30%DOD at 25°C
Operating Temperature	Nominal: 25°C (77°F) Discharge: -15°C - 50°C (5°F-122°F) Charge/Storage: -15°C - 40°C (5°F - 104°F)
Float Charging Voltage	--
Eq. Charging Voltage	14.4 - 15.0 Vdc/battery 25°C (77°F)
Self-Discharge	Less than 10% after 90 days, can be stored up to 6 months and 10 months with equalization charge* at 25C (77F); Full recharging is required before usage, and charged sooner if stored at higher temperature than 25C (77F).



# EVX Series

## EVX12340 Datasheet

12V Top Terminal VRLA-AGM

### Constant Current Discharge Characteristics Per Battery: Amperes (25°C, 77°F)

F.V/Time	30MIN	45MIN	60MIN	90MIN	2HR	3HR	4HR	5HR	6HR	8HR	10HR	20HR
10.02V (1.67 VPC)	33.6	24.7	19.8	14.5	11.5	8.19	6.49	5.34	4.57	3.57	3.02	1.80
10.50V (1.75 VPC)	31.8	23.6	19.1	14.0	11.2	8.02	6.36	5.22	4.45	3.46	2.90	1.72
10.80V (1.80 VPC)	30.8	23.0	18.7	13.8	11.0	7.86	6.27	5.14	4.38	3.41	2.86	1.69

### Constant Power Discharge Characteristics Per Battery: Watts (25°C, 77°F)

F.V/Time	30MIN	45MIN	60MIN	90MIN	2HR	3HR	4HR	5HR	6HR	8HR	10HR	20HR
10.02V (1.67 VPC)	404	296	238	173	139	98.3	78.0	64.1	54.8	42.8	35.3	19.0
10.50V (1.75 VPC)	382	283	229	168	135	96.3	76.5	62.6	53.4	41.5	33.9	18.0
10.80V (1.80 VPC)	370	276	224	165	132	95.1	75.5	61.8	52.7	40.9	33.4	17.6

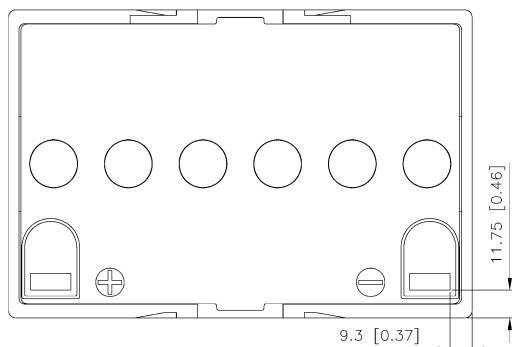

Detail A Drawing(3:1)

