



EVH Series

EVH12390 Datasheet

12V Top Terminal VRLA-AGM



Valve Regulated Lead Acid (VRLA) Battery

Maintenance-Free, Absorbent Glass Mat (AGM) Technology for Efficient Gas Recombination of up to 99%

Pure Lead Construction and Proprietary Elements

Designed for E-mobility or deep cycling applications

Built in Accordance with IEC 60254-1:2005 / IEC60254-2:2008, UL1973 Listed (MH66728) and UL1989 Recognized (MH14533)

Certified by TUV NORD according to ISO 9001:2015



Specifications

Voltage (Vdc)	12
Ah Capacity (8-Hr 1.75 VPC @ 25°C)	35.68
Ah Capacity (20-Hr 1.75 VPC @ 25°C)	39.20
Ah Capacity (8-Hr 1.80 VPC @ 25°C)	35.20
Max Charge Current (A)	11.70
Max Discharge Current (A)	400
Short Circuit Current (A)	987.5
Internal Resistance (mΩ)	Approx. 8.9
Terminal Type	B5 terminal to accept M6 nut & bolt
Terminal Torque	51.7±10.3 Kgf·cm / 44.9±9.0 Lbf·in / 5.10±1.0 N·m
Container Material	ABS (UL 94-HB)
Weight (kg. / lb., Approx.)	11.50 / 25.35
Length (L) (mm / in)	195.6±2.0 / 7.70±0.08
Width (W) (mm / in)	130.0±1.5 / 5.12±0.06
Height (H) (mm / in)	178.3±2.0 / 7.02±0.08
Design Life	400 cycles @ 100%DOD at 25°C 1800 cycles @ 30%DOD at 25°C
Operating Temperature	Nominal: 25°C (77°F) Discharge: -15°C - 50°C (5°F-122°F) Charge/Storage: -15°C - 40°C (5°F - 104°F)
Float Charging Voltage	--
Eq. Charging Voltage	14.4 - 15.0 Vdc/battery 25°C (77°F)
Self-Discharge	Less than 10% after 90 days, can be stored up to 6 months at 25°C (77°F); Fully recharging is required before usage, and charged sooner if stored at higher temperature than 25°C (77°F).



EVH Series

EVH12390 Datasheet

12V Top Terminal VRLA-AGM

Constant Current Discharge Characteristics Per Battery: Amperes (25°C, 77°F)

F.V/Time	30MIN	45MIN	60MIN	90MIN	2HR	3HR	4HR	5HR	6HR	8HR	10HR	20HR
10.02V (1.67 VPC)	38.5	27.7	22.9	17.5	14.2	10.3	8.19	6.87	5.51	4.60	3.81	2.06
10.50V (1.75 VPC)	36.4	26.6	22.0	16.8	13.7	10.1	8.04	6.71	5.36	4.46	3.67	1.96
10.80V (1.80 VPC)	35.4	26.0	21.6	16.6	13.50	9.93	7.94	6.62	5.29	4.40	3.60	1.91

Constant Power Discharge Characteristics Per Battery: Watts (25°C, 77°F)

F.V/Time	30MIN	45MIN	60MIN	90MIN	2HR	3HR	4HR	5HR	6HR	8HR	10HR	20HR
10.02V (1.67 VPC)	463	335	276	210	170	123	98.1	82.4	66.2	55.3	45.6	24.8
10.50V (1.75 VPC)	438	319	265	204	166	120	96.2	80.5	64.4	53.6	44.0	23.5
10.80V (1.80 VPC)	425	312	260	201	163	119	95.0	79.4	63.4	52.8	43.3	22.9

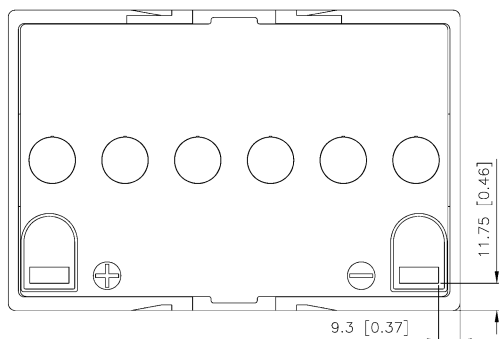

Detail A Drawing(3:1)

